

THE SKIN EFFECT AND BIO-ELECTRICAL IMPEDANCE ANALYSIS

There has been a great deal of debate as to whether Dr. Rife's electrical frequencies can penetrate the human or animal skin via metal electrodes. The disagreement has been that the electrical frequencies will only travel along the outside of the body, never penetrating through the skin and entering the body tissue. This incorrect myth or understanding has come about because people are applying the "Skin Effect" of an electrical copper wire to human skin or tissue as though they are made of the same material. This "Skin Effect" myth was started by people who only believed that a plasma ray tube could deliver Dr. Rife's frequencies. This scientific report dispels this myth. Below we will start with the scientific definition of the "Skin Effect.”:

“Skin effect is the tendency of an alternating electric current (AC), electrons to flow more at the outer surface of the wire rather than through the middle. The higher the frequency, the more the skin effect and the greater the resistance. Stranded wire produces less skin effect than solid wire, because there is more surface area. The skin effect enables copper-clad steel wire to be used. The steel adds cable strength, and the current flows mostly through the better-conducting copper.

The skin effect is due to opposing eddy currents induced by the changing magnetic field resulting from the alternating current. At 60 Hz in copper, the skin depth is about 8.5 mm. At high frequencies the skin depth becomes much smaller. Increased AC resistance due to the skin effect can be mitigated by using specially woven litz wire.”

If you read carefully you will notice that this definition of the "Skin Effect" only pertains to an electrical wire, not to human or animal skin or tissue. We must repeat that the "Skin Effect" does not mean human or animal skin or tissue. It only refers to the skin of a metal conductor such as a metal wire. If human or animal skin was made of metal then this definition would apply. Yet, people misquote this definition and use it to describe how electrical current passes through everything including biological tissue such as the human skin.

Usually the people who misquote the "Skin Effect" have only heard about it by word of mouth from someone else. Then this false understanding just keeps getting spread because people tend to believe what they are told rather than checking it out for themselves. These misinformed people do not understand that scientific studies called “Bio-electrical impedancemetry” or “Bio-electrical Impedance Analysis” have been done which show how electrical frequencies flow through human skin or tissue. These tests scientifically prove that the skin effect of a metal wire does not apply to human or animal tissue within the frequency ranges Dr. Rife used. In fact it does not pertain to frequency ranges that are much higher than those used by Dr. Rife.

Another education report that was published by Harvard Education Courses in 1997 discusses how frequencies are absorbed in the body. This report showed that penetration depth for fat and bone is nearly five times greater than for higher-water-content tissues. At frequencies between 300 and 3000 MHz, electromagnetic energy can penetrate into more deeply situated tissues, making it especially desirable for therapeutic applications. The frequency of maximal absorption is called the resonance frequency and for humans it is between 70 and 100 MHz.

Dr. Rife worked with frequencies from the audio range up to about 18 MHz or 18 million Hertz. This range of frequencies is very low compared to the 70 to 3000 MHz range. These reports show that there is no “Skin Effect” in any of these ranges especially below 70 MHz. Below is the link to the Harvard report.

[“Absorption of RF Radiation Link”](#)

After you have read this report and the Harvard report you will find the real question that should be considered is: What is the Cell Effect? The false concept that human or animal tissue is affected in the same manner as a metal wire only exists in the minds of those who have not read these scientific reports. This scientific report, given below, is presented to give documented factual information on this subject. It is only one of many scientific reports which have been done on "Bio-electrical Impedance Analysis." If anyone just takes the time to look on the internet they will find many other such scientific reports that give this same information.

This scientific "Bio-electrical Impedance Analysis" report along with all of the other scientific reports confirm that frequencies do pass through the human skin into the tissue of the body, using electrodes, as long as the proper methods are used. There are limits to frequency penetration depending on whether a low frequency (5,000 Hertz) is used or a high frequency (1,000,000 Hertz or 1 MHz) is used. These limits only apply to cell penetration. These reports show that low frequencies only go through the connective tissue where high frequencies can penetrate the cells of the body.

Because most of these types of reports are very technical we will give a simple explanation at the end of each section, in blue print, if one is needed. At the end of the report, at the bottom of this page, we will give a complete summary of this report. Below is the report with all of its scientific data. Also included is a link to another report with the same information about how 1 MHz is needed for full cell penetration.

<https://sites.google.com/site/antoniivorra/home/electrical-bioimpedance>

Bio-Electrical Impedance Analysis Report

Bio-electrical impedancemetry or Bio-electrical Impedance Analysis (B.I.A.) initiated in France by A.L. THOMASSET in 1962 today forms part of the arsenal of the means of exploration of biological tissues. Already widely diffused in the USA and the Anglo-Saxon countries, this method has a promising future. After a brief historical recapitulation, this work will present the basis on which the method was founded, followed by some examples illustrating its numerous applications in the medical field, as well as the perspectives opened up in biological research in general. In a word, bio-electrical **IMPEDANCEMETRY** is a simple technique allowing easy measurement of body water and its extra and intra-cellular distribution in the organism.

Water is the main component of the human body where it represents 58 to 62%, of the body weight. In many pathological cases this quantity varies. However, until now, because of the absence of simple means, it was not measured. Today, this measurement is at the disposal of all physicians thanks to **Bio-Electrical Impedance Analysis: B.I.A.**

The first concerned are nephrologists for the monitoring of hemodialysis, and nutritionists. But many other physicians are concerned by this work, as for example those in medical and surgical intensive care, those in units for the severely burned, cardiologists and those involved in metabolic disorders. Moving away from such specialties, other physicians and researchers in sports medicine, occupational medicine, thermal medicine, and of course in physiology and biology will find in this work many arguments allowing them to develop their activities.

Historical Background

It was by studying the electrical activity of the brain by EEG that A.L. Thomasset in Lyon from 1955 to 1960 observed that the differences of potential could be similar to the law of Ohm and comply to the formula: $U = R \cdot I$. This idea led the author to look for the value of R , the electrical resistance of the brain tissue, then step by step to measure that of the whole body. For this, the body being both an ionic and non-homogeneous conductor, it was necessary to use an alternating current and not a direct current. Because of this, the resistance studied took the name of impedance, a value expressed by the symbol Z . The equality $U = R \cdot I$ is therefore written $U = Z \cdot I$ i.e. $Z = U/I$, U being the difference of potential, I the intensity of the measurement current. Then, if we use for the measurement a current of constant intensity I the potential in volts that is collected between two electrodes is equivalent to Z multiplied by this constant $U = Z \cdot I$ and is representative of the impedance of the conductor. None-the-less, this measurement should be performed in certain precise conditions that we shall examine later.

Now as from the beginning of the study most of these conditions were fulfilled, as the measurements were systematically recorded in the morning, between 8 and 9am, in a medical department where men and women were hospitalized for various reasons, it allows us to confirm that the measurements were reproducible.

This reproducibility was the fundamental and determining quality without which the study could no longer be pursued. All the authors who had studied the problem before, since d'Arsonval, Cole and Curtis, Barnett, to mention only a few, placed without success the un-moistened electrodes on the skin a capricious barrier for the current that needs only to be traversed by using moistened electrodes or needle-electrodes inserted under the skin to avoid this pitfall.

Given this, the meaning of the body impedance measurements was a simple game thanks to the work of the school of F.D. Moore at Harvard, while H.P. Schwann in Philadelphia, Ch. Eyraud and J. Lenoir [15] of the C.N.R.S. in Lyon validated the study scientifically.

In defense of physicians, it should be admitted that, until now, they had no simple means at their disposal to perform such a measurement. Today, this means is now available to them through electrical impedance measured by a method that we developed as from 1962 and experimented in various fields of physiology and medical practice.

We trust that the readers will find in this presentation the basic elements of the method as well as some examples of applications liable to throw light on their own observations.

Explanation: Alternating current (AC) is used for biological tissue. Earlier experimenters were unable to read body impedance because they did not moisten the skin or insert needles. Today many body impedance devices, which do not use needles, are used to determine if there are any blockages in the electrical flow in the body. Many of these instruments, such as the Bio-Meridian an FDA approved device, use a metal probe to access meridians of the body. The skin must be moistened at each meridian point in order to check the impedance. Defibrillators which are used to electrically shock the heart use a conductive jell in order to prevent burning of the skin, allowing the electrical current to enter the body. Moisture is the key to getting frequencies into the body without the use of needles.

Electrical impedance

The word impedance comes from the Latin impedire meaning **to prevent, to stop from going on**. In terms of electricity, impedance signifies the resistance of a conductor when an electric current passes.

However, conventionally speaking, the term **resistance** refers to the obstacle to the **direct current**, and it is represented by the letter **R**. The terms **impedance** refers to the obstacle to the **alternating current** and it is represented by the letter **Z**. Impedance **Z**, as resistance **R**, is expressed in **ohms**.

Explanation: Resistance refers to the obstacle of (DC) direct current. Impedance refers to the obstacle of (AC) alternating current.

Electrical conductivity

The electric conductivity of a conductor is its capacity to conduct the current. It is called **conductance** for a direct current and **admittance** for an alternating current.

Conductance is equal to the inverse $1/R$ of the resistance. Admittance is equal to the inverse $1/Z$ of the impedance.

In both cases, conductivity is expressed in **mho** (the inverse of the word ohm). In practice, use has prevailed, and most often the designations resistance or impedance expressed in ohms are employed to define conductivity.

Resistivity of a conductor

This is the resistance that a sample of this conductor with a length and section equal to one unit opposes to an electric current passing through it between two electrodes each with a section equal to one unit and placed on two opposite faces of the volume thus defined of the sample to be measured.

Figure 3.1: Determination of the resistivity

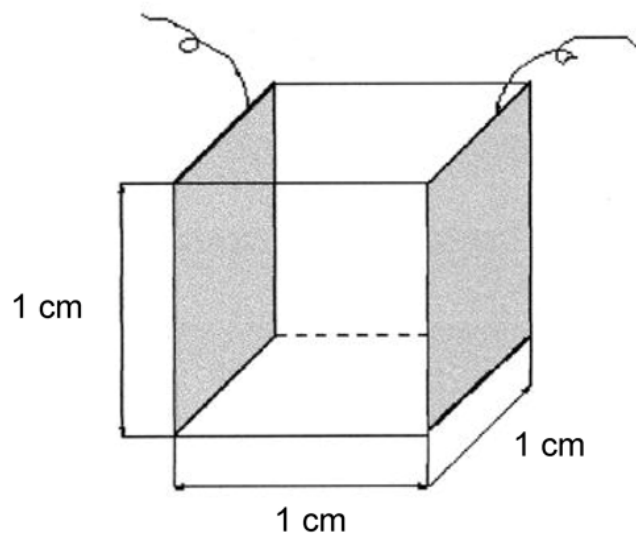

1 cm Example: The resistivity of copper is the resistance of a cube of this metal measuring 1 cm on each side, through which passes a current between two electrodes measuring 1 cm^2 placed on sides A and B of this cube.

Resistivity is conventionally expressed by the Greek letter ρ . It is measured by means of a direct current if we are dealing with an electric conductor such as iron or copper, and by means of an alternating current if it is an ionic conductor and furthermore non-homogeneous such as a biological tissue, but in this case resistivity varies with the frequency of the measurement current, and one should indicate the frequency of the current used in the following manner: ρ_{5kHz} or ρ_{1MHz} .

Explanation: Resistance depends on both material used (body tissue) and frequency used.

Notion of frequency of an electric current

A direct current has a null frequency. It passes through a conductor always in the same direction from the positive pole to the negative pole.

An alternating current is an oscillating current usually sinusoidal which passes through a conductor alternately in one direction then in the opposite direction, a certain number of times per second.

This number of times depends on the generator that produces it. It may vary from a few units (as is the case for domestic current of 50 Hz (Hertz), or cycles per second, in France), to several million cycles per second. This number is called current frequency and is expressed in cycles per second or in Hertz (Hz).

A current is said to be of low frequency (**LF**) when this frequency is below 50,000 Hertz, of (**MF**) medium frequency between 50,000 and 500,000 Hertz, and high frequency (**HF**) above 500,000 Hertz.

When studying body impedance the current used in (**LF**) low frequency is 5,000 Hertz or 5 KHz (kilohertz), and in (**HF**) high frequency 1,000,000 Hertz or 1 MHz (1 Megahertz).

Explanation: Direct current (DC) has a null frequency. This means the energy flow can stop in the body after a period of time because it is only going in one direction from the positive pole to the negative pole. Alternating current has no null frequency because it alternates back and forth to each pole.

Why use an alternating current to measure the impedance of a biological tissue?

Essentially for two reasons:

Because a biological tissue is an **ionic conductor**: it is known that electrical conduction in a material occurs through charge carriers, which may be electrons, such as is the case for metals; or free ions in suspension in solutions, as is the case for biological tissues.

If a direct current is passed through an ionized solution, the well-known phenomenon of polarization occurs, i.e. very rapidly at the level of each electrode a double layer of ions is deposited which acts as an insulator and prevents the current from passing. Therefore, a direct current cannot be used to measure the resistance of such a conductor.

Because it is a **heterogeneous conductor**: i.e. it is composed of both **resistive elements and** [noref] **capacitive elements** diversely associated. Whereas the resistive elements allow the alternating current to pass whatever its frequency, the capacitive elements allow the alternating current to pass only if it has a **high frequency**.

Such that the opposition encountered by electricity to circulate in a biological conductor must necessarily be studied by means of an alternating current. Thus it is indeed an impedance.

Explanation: Direct current known as (DC) current travels in only one direction. Direct current cannot be used to measure the resistance of the human body. DC current causes ions to build up eventually causing polarization. This can cause heating in tissue if one is not careful. Alternating current is safer to use in biological tissue and will allow the passage of high frequencies through the body tissue including the bone.

Capacitive element

This is an element able to store electrostatic charges. A condenser with its two armatures (fig3.2) separated by an insulator (di-electric) is a **capacitive element**.

Figure 3.2: Condenser

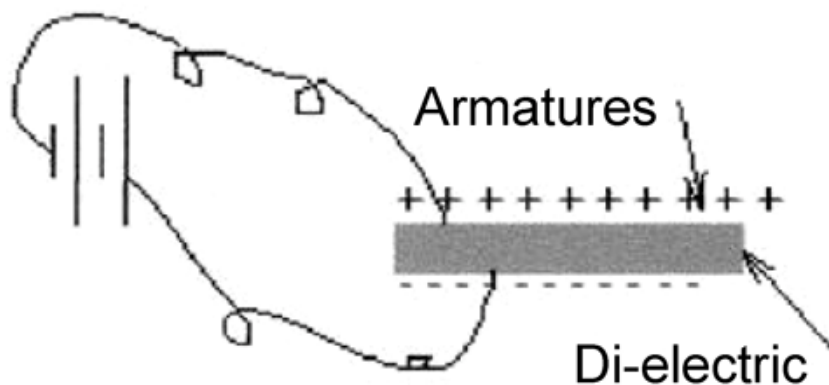

In biological tissues the cellular content represents one of these armatures; the interstitial fluid represents the other. They are separated by the cell membrane which plays the role of insulator or di-electric. In common language in electricity to designate a condenser the term capacity is often used, the object being designated following its function. This is an improper use of language; in fact, the capacity C_p represents the ability of a conductor to receive a charge Q .

Explanation: The body can receive an electrical charge.

Capacity and impedance of a condenser

This capacity is evaluated in farads and depends on the form, the dimensions of the di-electric as well as the nature of the di-electric.

A condenser (capacitive element) interrupts the circulation of the direct current, for as soon as its armatures are charged, one positively, the other negatively, the current no longer passes.

On the other hand, an alternating current appears to cross the obstacle represented by the di-electric of the condenser. In reality, the condenser acts on the current by retarding it by a half-period (90% or $k/2$) (fig 3.3).

Figure 3.3: Behavior of a condenser in alternative current.

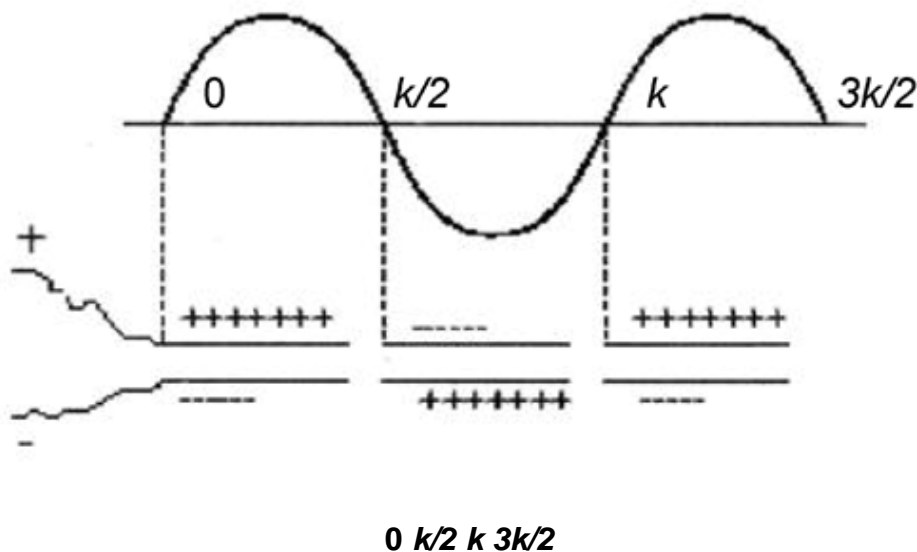

The condenser impedance ($1/C2kf$) is all the higher as the frequency is lower and reciprocally it tends towards zero when the current frequency tends to infinity. It may be considered that the condenser conducts in a normal fashion the alternating current, which is true in practice if not in theory.

These notions concerning the properties of condensers show why a low frequency current does not cross the membranes, whereas they are crossed all the more easily as the current frequency is high. A condenser can accumulate a certain electric charge Q whose value is given by the formula:

$Q = Cp \times U$, where U is the difference of potential between the armatures, Such that : $Cp = Q/U$.

A difference of potential U represents the difference of concentration of the charge carried between the two poles of a resistance conductor R when this conductor is traversed by a current of intensity I (Ohm's law $U = R \times I$)

Explanation: The lower the frequency (1 to 50,000 Hertz) the more difficulty the frequency will have in penetrating into the body. Moisture is critical for the use of low frequencies. High frequencies (1,000,000 Hertz or 1 MHz) will penetrate the body without any resistance. Though moisture is not as critical for the passage of high frequencies it should still be used with electrodes.

Impedance variation of a biological tissue according to the frequency of the measurement current

When one studies the impedance Z of a biological conductor it may be observed that it varies according to the frequency of the measurement current. **The higher the frequency** the more easily the current passes and consequently, **the lower the impedance**. If these variations are recorded, we obtain a curve whose general aspect is represented in figure 4.1.

Figure 4.1: Evolution of the modulus of impedance $|Z|$ with respect to the frequency F

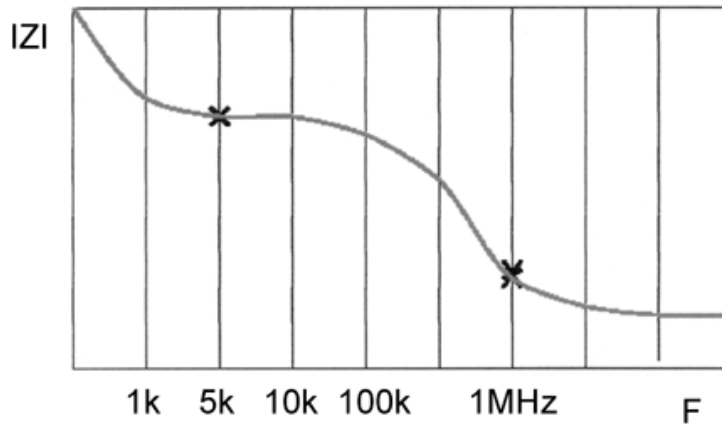

It is the aspect that is taken on by the variations of the impedance modulus of a biological tissue as represented schematically in figure 4.2 where cells can be seen surrounded by their membranes enveloped in the extra-cellular fluid as well as the lines indicating the (**LF**) low frequency (5,000 Hertz) and (**HF**) high frequency (1,000,000 Hertz or 1 MHz) current.

It may be observed that there is an analogy between figure 4.2a and figure 4.2b which shows an electric circuit involving the association of a series resistance (R_s) with a capacitive element (C_p) and an-other resistance (R_p) in parallel. The impedance curve of this classical circuit is represented in figure 4.3 with respect to the frequency. This circuit is called an electronic filter as, depending on the value of the capacity C , it does not allow the electric currents to pass except above a given frequency.

Figure 4.2: Analogy between a biological tissue and a filtering network

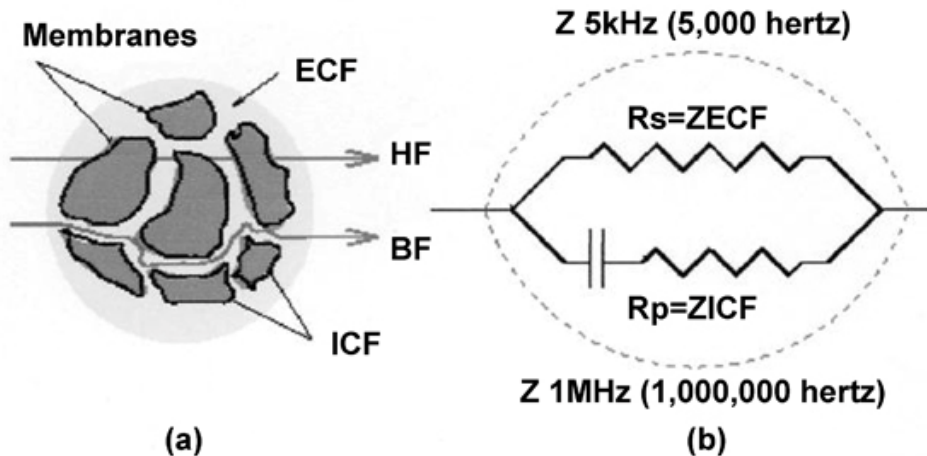
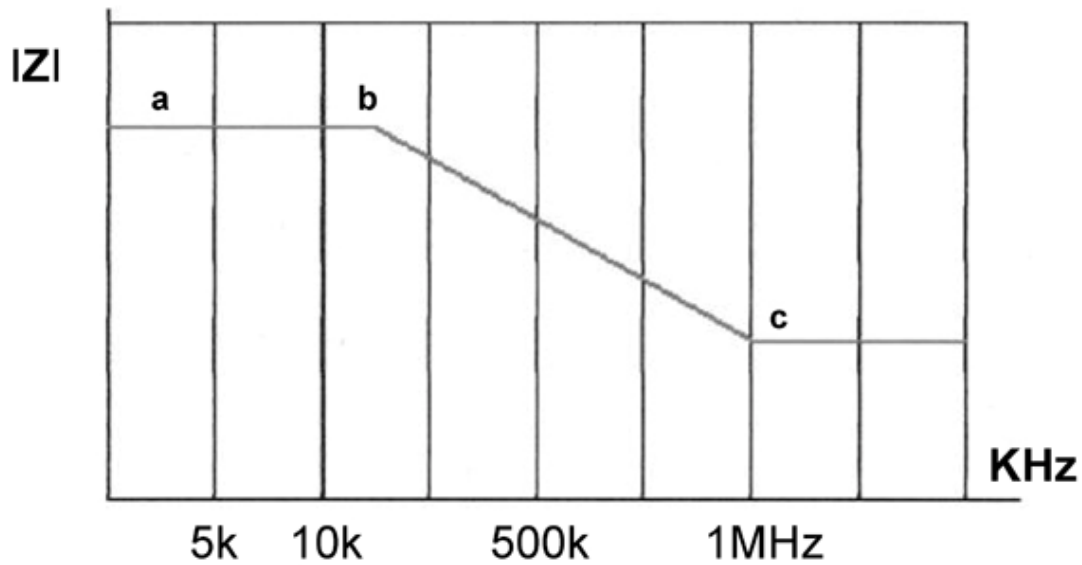

Figure 4.3: Evolution of the impedance modulus $|Z|$ with respect to the frequency for the circuit of figure 4.2



In fact, in the biological tissue the membranes act as a di-electric or an insulator separating two conducting media, the extra-cellular fluid ($ECF=Rs$) and the intra-cellular fluid ($ICF=Rp$) which fulfill the role of armatures of the biological condenser. It may be added that the membranes are not a good insulator, and that the condenser they make up is a leakage condenser.

To circulate between **A** and **B** (Fig 4.2) a low frequency current 10 KHz (10,000 Hertz) can only take the path Rs , i.e. must pass between the cells. The difficulty encountered is relatively great and the impedance corresponds to the part **a** and **b** of figure 4.3

Between 10 kHz (10,000 Hertz) and 500 kHz (500,000 Hertz) the current takes more and more the path ($C+Rp$) of figure 4.2 corresponding to the part **b** and **c** of figures 4.1 and 4.,.3. i.e. it penetrates more and more easily into the cells (Fig.4,4b).

Figure 4.4: Path of the current through a cell

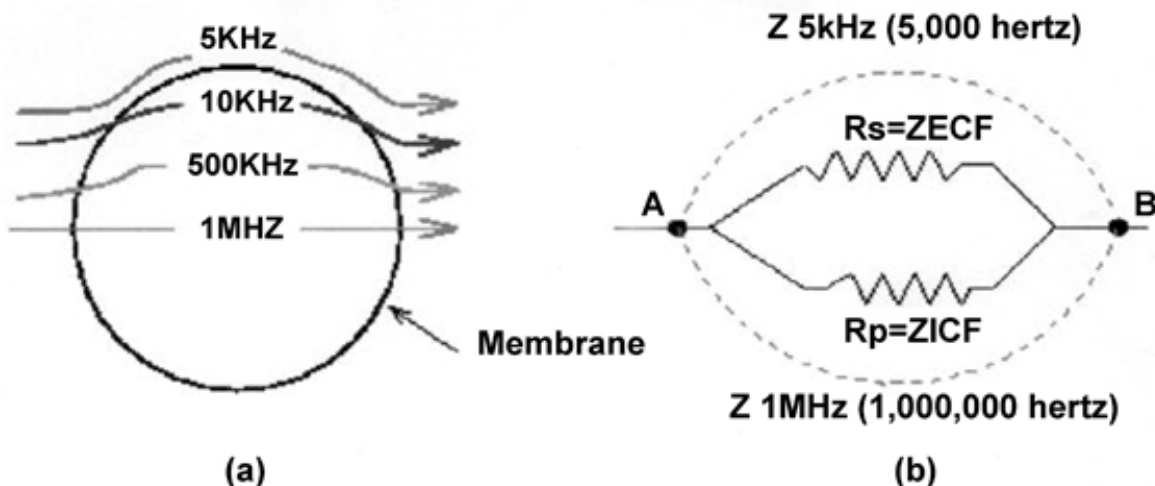

When the frequency is high enough the capacitive effect **Cp** (Fig. 4.2b) corresponding to the cellular membranes is cancelled and the current passing between **A** and **B** takes the two resistive pathways **Rs** and **Rp** (fig. 4.4b) such that at the moment we are dealing with a system to which we may apply the formula of Kirchoff:

$$\frac{1}{Z_{1MHz}} = \frac{1}{Z_{5kHz}} + \frac{1}{R_p} = \frac{1}{Z_{ECF}} + \frac{1}{Z_{ICF}}$$

This formula will be used later, when estimating the cellular content.

In practice, we have indeed chosen the frequency 5 kilo-hertz (5,000 Hertz or cycles per second) to represent the low frequencies (**LF**) and 1 MHz (1,000,000 Hertz or cycles per second) to represent the high frequencies (**HF**)

The frequency 5 KHz (5,000 Hertz) was chosen because it represents the mean between 1 KHz (1,000 Hertz) and 10 KHz (10,000 Hertz), i.e. that at 1 KHz (1,000 Hertz) there still subsists a slight polarization of the electrodes (Fig. 4.1) and that at 10 KHz (10,000 Hertz) the current begins to enter into the cells (Fig. 4,4a).

The frequency 1 MHz (1,000,000 Hertz) was adopted as at this frequency the capacitive effect of the membranes is practically null. Further, it is difficult to control the current beyond this frequency without parasiting the conductors, either the equipment, or the body to be measured, the errors liable to occur being greater than the precision sought for.

Explanation: The higher the frequency the less the resistance. At about 1 MHz (1 million cycles per second or Hertz) there is no more resistance in the biological tissue of the body. Low frequencies below about 10,000 Hertz only travel through the connective tissue of the body. At about 10,000 Hertz frequencies begin to penetrate the outside layers of the cell. This scale gradually goes up so that at about 100,000 Hertz penetration into the cell is very noticeable. From 100,000 Hertz to 1,000,000 Hertz (1 MHz) penetration into the cell is significant until full penetration is achieved at 1 MHz. This understanding of how frequencies work in the body explains why a carrier frequency of at least 1 MHz should be used.

It should be understood that all the tests done for this report were done with a sine wave waveform. A square wave waveform creates higher frequency harmonics that may have some cell penetration even when using a low frequency.

Resistivity of a biological tissue

The resistivity of tissues varies according to the frequency of the measurement current.

In **LF** (low frequency) the cells that are concerned in a tissue volume unit act as insulators, enclosed in a liquid conductor of resistivity P_e . (Fig. 4.5a). **A current with a weak LF (low frequency) must necessarily pass between them.** The more the cells are packed together the greater the resistance (here the resistivity PLF since we are measuring a unit of tissue volume), and conversely, the fewer the cells in this unit of volume, the more easily the current can pass and in this case PLF is close to P_e : (fig. 4.5b).

Figure 4.5: A low frequency current (5,000 hertz) across a biological tissue

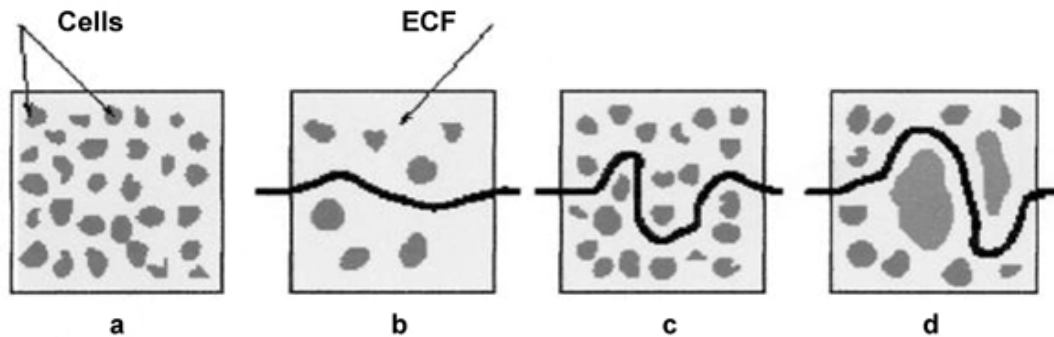

It can therefore be understood that PLF of a tissue is a function of P_e and γ the latter factor being a factor of form. It is the form that should be taken on by the electric current to pass through the tissue. (Fig. 4.5c).

Normally the tissue of each organ has a texture, i.e. a constant factor γ , and if we accept that P_e of the plasma is constant, the mean body resistivity PLF of all tissues taken together is constant in the normal state.

It is the same in all subjects in good health, except, as will be seen later, in lean or obese subjects where non-conductive fatty inclusions are more or less great in relation to the normal state (Fig.4.5d) and influence the tortuosity of the electric field in **HF** (high frequency) as in **LF** (low frequency).

In HF (high frequency), the measurement current at 1 MHz (1,000,000 Hertz), cancels the capacitive effect of the cellular membranes such that to pass through a unit of tissue volume the current uses both **ECF** and **ICF**.

Figure 4.6: A high frequency current across a biological tissue

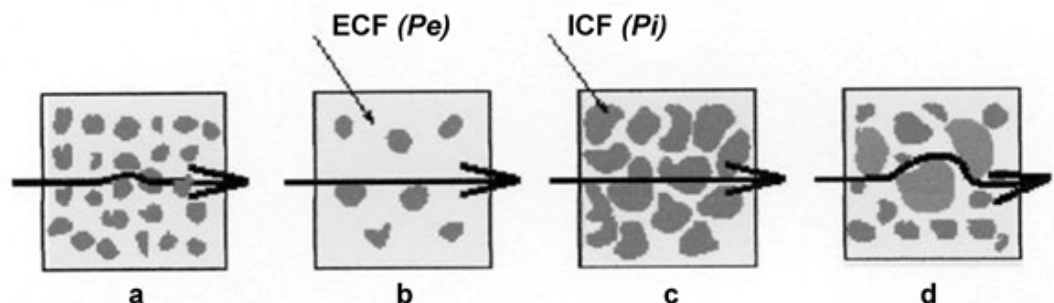

The resistivity is therefore a function of P_e (ECF) and P_i (ICF) according to a proportion that depends on the number of cells in the unit of tissue volume measured (Fig 4.6a).

In the case of extra-cellular edema there are fewer cells in the unit of tissue volume measured, and the influence of P_e predominates over P_i in relation to the normal state (Fig. 4.6b).

More rarely, we may be faced with a cellular edema, in this case the influence of P_i predominates in relation to the normal state. Such a case is often encountered in renal pathology (Fig. 4.6c).

It can be seen from these examples that PHF depends more on P_e and P_i than on the factor γ . However, in the case of leanness or obesity this factor γ plays as much a role as in LF (low frequency), diminishing or augmenting PHF (Fig. 4.6d).

Explanation: Organ tissues are of different density. The denser the tissue the greater the resistance to low frequencies. The illustrations in this report show that low frequencies go around the cells and high frequencies go through the cells. This is because there is no resistance in penetrating the skin or cells when using high frequencies. This again shows the benefit of using a carrier frequency of at least 1 MHz (1,000,000 Hertz).

Description

The skin was the obstacle to be surmounted before approaching the body composition by impedancemetry. Although directly accessible to the physician the skin is a relatively little known organ. Schematically, it is made up of three parts: the epidermis, the dermis and the hypodermis.

Figure 4.7: Schematic organization of the skin

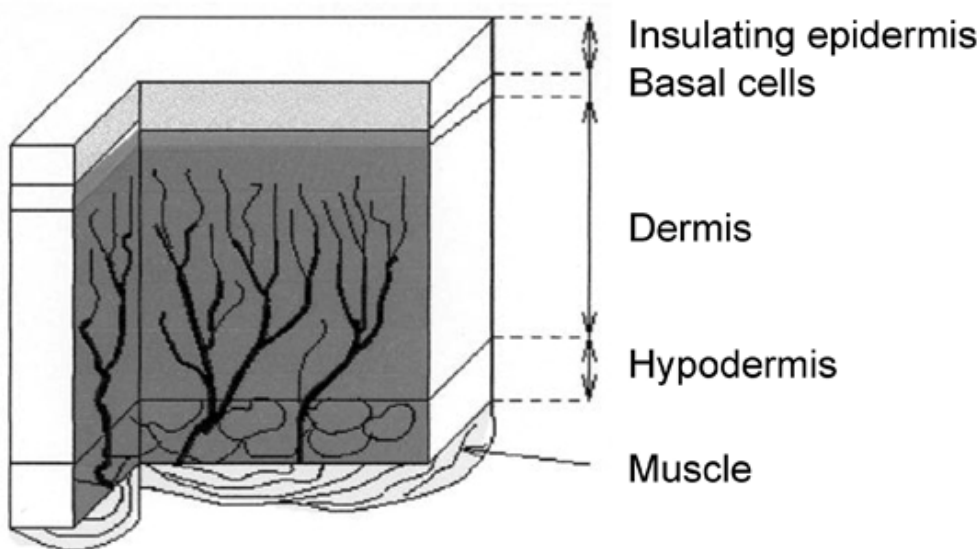

The epidermis consists of several superimposed layers: basal cells of the deep layers, with a nucleus, migrate upwards to form a second rather thick granular layer, well delimited, above which there is a third layer which is the corneum, made up of non-nucleated cells, overlapping each other, fused together in depth and open to the external environment, in the same way as microscopic

scales. These three layers are pierced by more or less numerous canals whose role is to evacuate perspiration and hairs whose *raison d'être* is poorly understood.

The dermis underlying the epidermis is the nourishing part of the skin. It contains the blood capillaries bathed in a network of collagen fibers. This layer lies on the hypodermis.

The hypodermis is composed of fatty lobules between which vessels nourishing the dermis work their way. Its thickness is variable, greater in women than in men. It is the hypodermis that makes up the *coating* an important part of the Fatty Mass, and it is the double thickness of the hypodermis that is measured by the method of skin folds.

Whereas the anatomical structure of the skin is well known, its physiology still hides uncertainties, but it may be said without contest that the epidermis alone ensure 90% of the functions of the skin. Besides the role of barrier separating the external from the internal environment and serving as a container for the fluids, the epidermis prevents the penetration into the organism of noxious products and bacteria, at the same time ensuring the evaporation of water and contributing to the body heat regulation.

Skin impedance

There is little data available on this subject. It is only known that the skin is an insulator for weak currents of low frequency (5,000 Hertz), and that it can be easily passed through by the same currents but at high frequency (1,000,000 Hertz or 1 MHz).

Figure 4.8: Equivalent electric diagram for the skin

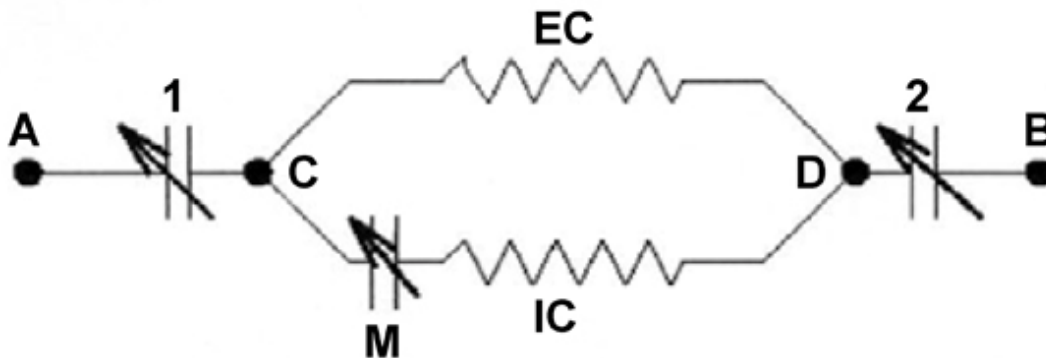

This property is due to the corneal layer of the epidermis, it varies according to the anatomical regions and according to the time of day for the same region. The epidermis acts as a leakage dielectric. With the electrodes placed on its surface on the one hand and the sub-epidermal conducting layers on the other hand it forms two variable condensers, as shown in fig. 4.8 which illustrates that a weak LF

(5,000 Hertz) current cannot circulate between A and B, as on this trajectory there are two obstacles 1 and 2 representing the epidermis.

On the other hand, if the same low frequency (5,000 Hertz) current enters by means of moistened electrodes or needles placed under the skin in **C** and **D**, it can then follow the pathway **E-C**, but it cannot take the pathway **I-C** interrupted by the condenser **M** created by the cellular membranes. To explore the pathway **E-C** and **I-C**, the measurement current should necessarily have a high frequency (1,000,000 Hertz or 1 MHz).

Explanation and summary: The skin is a good insulator. It is difficult for low frequencies to pass through it. The skin does have moisture in it. Some people have very moist skin and others have very dry skin. It takes higher voltage to penetrate dry skin than wet skin. Moisture is the determining factor for penetration through the skin into the body at low frequencies (5,000 Hertz). Once the frequency enters the body the determining factor of penetration into the cell is the frequency used. This report shows that low frequencies go around the cells, through the connective tissue, while high frequencies penetrate both the cells connective tissue and bones.

Bio-electrical Impedancemetry or Bio-electrical Impedance Analysis tests have shown that there is no skin effect when the proper methods are used. They also show that a carrier frequency of at least 1 MHz (1,000,000 Hertz) is necessary to penetrate the cells of the body when using low frequencies. Audio frequencies are generally considered to be below 20,000 Hertz. These frequencies need a carrier frequency to enter into the cell.